



# PRESSURE SWITCHES

**FLAMEPROOF + WEATHERPROOF**

## GR SERIES

- **GOOD REPEATABILITY**
- **TAMPERPROOF SET POINT ADJUSTER WITH LOCKING DEVICE**
- **OVERTRAVEL STOP**
- **RUGGED DESIGN**



**Model 201 in GR Flameproof Enclosure**

GR series Pressure Switches is a SWITZER mainstream product range for switching upto 700 bar and includes sensors for vacuum, compound and positive ranges with high overload protection. Precision mechanisms are of stainless steel for arduous atmospheres and high humidity. Enclosures, sensing elements and switching modes can be combined to offer the

variety needed to suit the demands of rapidly expanding industrial processes. Precise and accurate operation is obtained by using time proven seamless hydraulically formed bellows, diaphragm or diaphragm sealed piston. Setpoint is continuously adjustable over the instrument range. A min-max scale is provided for setting guidance.

## GENERAL SPECIFICATIONS

<b>Enclosure</b>	Aluminium Pressure Die Cast, weatherproof to IP:66 & flameproof to Gr.IIA, IIB or IIC ( <i>Note 1</i> )	<b>Ambient Temp.</b>	(-) 10°C to (+)60°C ( <i>Note 11</i> )
<b>Ranges</b>	Several std. ranges, from full vacuum to 700 bar	<b>Max. Working Temperature</b>	SS Bellows 170°C ; PB Bellows 110°C 316L SS diaphragm 110°C Neoprene diaphragm 95°C Diaphragm sealed piston (-)20 to +60°C
<b>Sensor</b>	Phosphor Bronze / 316 L SS Bellows 316L SS / Neoprene Diaphragm 316 SS Diaphragm sealed piston	<b>Connection Process</b>	For higher temperatures use longer impulse lines. ( <i>Note 12</i> ) Ask for piping nomogram #441184-4 1/4" NPT(F) direct for 201, S21, S24 & 021 1/4" or 1/2" NPT(F) direct for 204. Other sizes through Adaptor. Flanged connection for 208. For details refer ordering matrix.
<b>Wetted Parts</b>	Refer page 2.	<b>Electrical</b>	3/4" ET(F) std. & 1/2" NPT(F) optional. Dual Entry optional
<b>Repeatability</b> ( <i>Note 3</i> )	± 0.5% FSR – Model 201 ± 1% FSR – Models 204, 208, S21 & S24 ± 2% FSR – Model 021	<b>Mounting</b>	Back panel / wall / field
<b>Switching Element</b>	Instrument quality SPDT (Form C) Microswitch. ( <i>Notes 9 &amp; 10</i> )	<b>Conformity</b>	Generally to BS 6134 :1991
<b>Differential</b>	Fixed, non adjustable. For exact values ask for On-Off Differential Tables.		

## ORDERING MATRIX

### ENCLOSURE

Aluminium die cast flameproof cum weatherproof. CIMFR approved to Gr.IIA, IIB & IIC of IS:2148:2004 for flameproofness and IP:66 for weatherproofness. \_\_\_\_\_ **GR**

### MODEL

Seamless bellows actuated with low non adjustable on-off differential — **201**

316L SS diaphragm operated with overpressure upto 100 bar (200 bar optional) with differential as above \_\_\_\_\_ **204**

Similar to 204 but with ANSI 1½" #300 RF or 2" #150 or 300 RF flange. Direct actuation by a 316L SS diaphragm. More responsive than using a chemical seal filled system and suitable for Viscous media. \_\_\_\_\_ **208**

Diaphragm sealed piston actuated. Fixed low differential with maximum working pressure upto 155 bar as per table 2 \_\_\_\_\_ **S21**

Same as above but with MWP:1000 bar \_\_\_\_\_ **S24**

Elastomer diaphragm actuated. For low / ultra low range spans with fixed differential \_\_\_\_\_ **021**

### MATERIALS OF WETTED PARTS

#### Models 201

Phosphor Bronze Bellows with brass wetted parts \_\_\_\_\_ **01**

316L SS Bellows with 316 SS wetted parts \_\_\_\_\_ **02**

316L SS Bellows with 316 SS wetted parts to NACE MR-01-75 \_\_\_\_\_ **0N**

Monel bellows with Monel Wetted Parts \_\_\_\_\_ **0M**

#### Models 204, 208, S21 & S24

316L SS Diaphragm with 304 SS wetted parts and Nitrile 'O' Ring \_\_\_\_\_ **04**

316L SS Diaphragm with 316 SS wetted parts and Nitrile 'O' Ring \_\_\_\_\_ **02**

316L SS Diaphragm with 316 SS wetted parts and Viton® 'O' ring to NACE MR-01-75 \_\_\_\_\_ **0N**

Monel Diaphragm with Monel wetted Parts and Nitrile 'O' ring \_\_\_\_\_ **0M**

316LSS Diaphragm with 316 SS wetted parts of welded\*\* construction — **W2**

#### Model 204 only

316L SS Diaphragm + 304 SS wetted parts + Teflon® 'O' Ring and backup Sheathing for special services \_\_\_\_\_ **T4**

316L SS Diaphragm + 316 SS wetted parts + Teflon® 'O' Ring and backup Sheathing for special services \_\_\_\_\_ **T2**

#### Model 208 only

316L SS Diaphragm + 304 SS wetted parts with Teflon® Insert and Sheathing for Chlorine service \_\_\_\_\_ **T4**

#### Models S21 & S24 only

Monel diaphragm, Nitrile 'O' ring and 316 SS wetted parts. \_\_\_\_\_ **M2**

Monel diaphragm, Viton® 'O' ring and 316 SS wetted parts for NACE MR-01-75 \_\_\_\_\_ **MN**

Monel diaphragm and Monel wetted parts – Welded\*\* construction for NACE MR-01-75 \_\_\_\_\_ **MW**

\*\* For Model S21 & S24 reduced risk against leakage under extreme or exceptional conditions the diaphragm is welded to the pressure housings eliminating the 'O' ring.

#### Model 021 only

Neoprene diaphragm and cast Aluminium wetted parts \_\_\_\_\_ **N5**

Neoprene diaphragm and 304 SS wetted parts \_\_\_\_\_ **N4**

Neoprene diaphragm and 316 SS wetted parts \_\_\_\_\_ **N2**

**Note :** EPDM, Silicone and Nitrile diaphragms are optionally available

### RANGE CODE

Models 201 / 204 / 208 refer Table 1 \_\_\_\_\_

Models S21 / S24 refer Table 2 \_\_\_\_\_

Models 021 refer Table 3 \_\_\_\_\_

### SWITCH CODE AND RATING

Refer Table 4 \_\_\_\_\_

### ELECTRICAL ENTRY CODE

Refer Table 5 \_\_\_\_\_

\* Viton® is a registered trademark of DuPont Dow Elastomers  
Teflon® is a registered trademark of E.I.DuPont de Nemours and Company

## RANGE CODE & AVAILABILITY

Table 1 : Models 201 / 204 / 208

RANGE CODE	RANGE	MWP (bar)		
		201	204	208
A1K	- 1 to 0 bar	4	100	--
A2K	- 0.5 to +0.5 bar	4	100	--
COK	- 1 to +1.5 bar	4	--	--
D4C	5 to 50 mbar	2	100	▲
D5C	7.5 to 75 mbar	2	--	--
D8D	10 to 100 mbar	2	100	▲
A3B	5 to 200 mbar	2	--	--
A3C	5 to 250 mbar	2	--	--
A3K	0.05 to 0.16 bar	4	--	--
A4K	0.08 to 0.4 bar	4	100	▲
A5K	0.2 to 1 bar	4	--	--
C1K	0.1 to 1.1 bar	4	--	--
C2K	0.2 to 2 bar	4	--	--
A6K	0.4 to 4 bar	8	100	▲
C3K	0.6 to 6 bar	9	--	--
A7K	1 to 10 bar	15	--	--
A8K	1.6 to 16 bar	25	--	--
A9K	2 to 20 bar	25	--	--
C4K	8 to 32 bar	36	--	--
B1K *	10 to 40 bar	50	--	--
B2K *	10 to 60 bar	80	--	--
B3K *	15 to 75 bar	80	--	--
B4K	0.3 to 1.6 bar	--	100	▲
B7K	0.7 to 7 bar	--	100	▲
P8B	1.5 to 15 bar	--	100	▲
D3B	2.5 to 25 mbar	--	100	▲
X8K	-1000 to 0 mmWc	--	100	--
X9K	-200 to +200 mmWc	--	100	--

**Notes:** \* Ranges B1K, B2K & B3K are not available with Ph. Br. Bellows.

▲ For Model 208 MWP restricted to Flange rating.

Table 2 : Models S21 / S24

RANGE CODE	RANGE (in bar)	MWP (bar)	
		S21	S24
G3	(-)1 to (+) 1.5	15	---
DB	0.25 to 1.6	27	---
DC	0.4 to 2.5	27	600
DE	1 to 6	27	600
EA	1.6 to 10	70	600
EB	2.5 to 16	70	600
EC	4 to 25	110	600
ED	10 to 40	110	600
FA	10 to 100	155	600
U7	7 to 160	---	1000
V7	25 to 250	---	1000
W7	50 to 400	---	1000
Y4	100 to 700	---	1000

**Table 3 : Model 021**

RANGE CODE	RANGE	MWP (bar)
B3X	0 to 2.5 mbar	0.5
B5D	0.5 to 5 mbar	0.5
B7D	1 to 10 mbar	0.5
C2D	2.5 to 15 mbar	0.5
D3B	2.5 to 25 mbar	0.5
D4C	5 to 50 mbar	0.5
D5C	7.5 to 75 mbar	0.5
D8D	10 to 100 mbar	0.5
F1D	40 to 400 mbar	1
A5K	0.2 to 1 bar	4
G8B	0.16 to 1.6 bar	4
A6K	0.4 to 4 bar	7
B5X	-5 to 0 mbar	0.5
B7X	-10 to 0 mbar	0.5
C2X	-20 to 0 mbar	0.5
C5X	-25 to 0 mbar	0.5
X5K	-50 to 0 mbar	0.5
X8K	-100 to 0 mbar	0.5
B3D	-2.5 to +2.5 mbar	0.5
XB7	-10 to +10 mbar	0.5
X9K	-20 to +20 mbar	0.5
D4X	-50 to +50 mbar	0.5

**Table 4 : SWITCH CODE, RATING & AVAILABILITY (Note 9)**

SWITCH CODE (SPDT)	AC RATING	DC RATING IN AMPS						AVAILABILITY OF SPDT IN MODELS	AVAILABILITY OF DPDT IN MODELS
		RESISTIVE			INDUCTIVE				
		220V	110V	24V	220V	110V	24V		
2	5A 250 / 125V	0.25	0.5	5.0	0.10	0.25	3.0	201, 021	201, 021
D	15A 250 / 125V	0.2	0.4	2.0	0.02	0.03	1.0	201, 204, 208, S21, S24, 021	201, 204, 208, S21, S24, 021
3	15A 250 / 125V	N.R.	N.R.	N.R.	N.R.	N.R.	N.R.	201, 204, 208, S21, S24, 021	201, 204, 208, S21, S24, 021
4	1A 125V	N.A.	0.5	0.5	N.A.	0.25	0.25	201, 204, 208, S21, S24, 021	201, 204, 208, S21, S24, 021
5	5A 250 / 125V	0.2	0.4	4.0	0.2	0.4	3.0	201, 204, 208, S21, S24, 021	201, 204, 208, S21, S24, 021
6	0.1A 125V	N.R.	N.R.	0.1	N.R.	N.R.	N.A.	201, 204, 208, S21, S24, 021	201, 204, 208, S21, S24, 021
7	N.R.	N.R.	N.R.	1.0	N.R.	N.R.	0.5	201, 204, 208, S21, S24, 021	201, 204, 208, S21, S24, 021
8	5A 250 / 125V	N.A.	N.A.	5.0	N.A.	N.A.	3.0	201, 204, 208, S21, S24, 021	201, 204, 208, S21, S24, 021
J	5A 250V	N.A.	N.A.	5.0	N.A.	N.A.	3.0	201, 204, 208, S21, S24, 021	201, 204, 208, S21, S24, 021
K	1A 125V	N.A.	N.A.	1.0	N.A.	N.A.	0.5	201, 204, 208, S21, S24, 021	201, 204, 208, S21, S24, 021
S	5A 250 / 125V	0.25	0.5	3.0	0.1	0.2	2.0	201, 204, 208, S21, S24, 021	201, 204, 208, S21, S24, 021

Codes 2, 3, & D – For General purpose usages.  
 Code 4 – With Gold alloy contact.  
 Code 5 – For General purpose with good DC rating.  
 Code 6 – With Gold alloy contact (Low Rating).  
 Code 7 – Environmentally sealed switch with Gold plated contact.  
 Code 8 – Environmentally sealed switch with Silver alloy contact.  
 Code J – Hermetically sealed, inert gas filled with Silver alloy contact.  
 Code K – Hermetically sealed, inert gas filled with Gold plated contact.  
 Code S – IP:67 sealed microswitch with silver – Nickel contact.  
 For DPDT, change switch code '3' to '33', '4' to '44', etc., while ordering  
 N.A. – Not Available      N.R. – Not Recommended

Note : For on-off differentials; ask for **Differential** tables.

**Table 5 : ELECTRICAL ENTRY CODE**

Size *	Entry	
	Single	Dual
3/4" ETF	A	M
1/2" NPTF	B	N
M20 x 1.5 F**	D	P

\* Cable gland available on request.  
 \*\* Cable Entry is optional. Available on request.

**OPTIONS / ACCESSORIES**

- Damping coil for minimising process pulsations — increases instrument's life many times.
- Breather / Drain for flameproof enclosures
- Snubbers, pigtail syphons, over-range protectors.
- Brass / 316 SS double compression cable glands to suit cable OD of 1/2", 15 mm & 17 mm.
- Degreasing for Oxygen service & special parts for Ammonia service.

**NOTES**

- Gr.IIA & IIB of IS:2148 is equivalent to NEC CL.1, Gr.C & D. Gr.IIC of IS:2148 is equivalent to NEC CL.1, DIV.1, Gr.A & B.
- Enclosure is weatherproof only if cover 'O' ring is retained in position and flameproof only if proper FLP cable gland is used. It is recommended to procure cable glands along with instruments to avoid neglect of it while installation.
- Accuracy & Repeatability are not different for all blind pressure switches. A shift of ±2% may be observed in setpoint when pressure falls from full static pressure. Settings will also shift with varying temperature.
- The instrument is calibrated in the mounting position as depicted in the drawing. Mounting in any other direction will cause a minor range shift, especially in low and compound ranges. Ranges above 1 bar will not experience this shift.
- A pressure switch is a switching device and not a measuring instrument. For this reason, Test Certificates will not contain individual ON-OFF switching values at different scale readings.
- Select working range of the instrument such that the set value lies in the mid 35% of the range i.e., between 35% and 70% of range span.
- For switching differential values please ask for **Differential** tables. Switching differentials furnished are nominal values under test conditions at mid-scale and will vary with range settings and operating conditions.
- On and off settings should not exceed the upper or lower range value.
- DPDT action is achieved by two SPDT switches synchronised to practical limits i.e., ±2% of FSR. Deadband for DPDT contacts are higher than that of SPDT as the force required to actuate the contacts are more. Please refer respective range table for exact values.
- Contact life of microswitches are  $5 \times 10^5$  switching cycles for nominal load. To quench DC sparks, use diode in parallel with inductance, ensuring polarity. A 'R-C' network is also recommended with 'R' value in Ohms equal to coil resistance and 'C' value in micro Farads equal to holding current in Amps.
- Ambient temperature range: All models are suitable for operating within a range of ambient temperature from (-) 10°C to (+) 60°C provided the process does not freeze within this range. Below 0°C, precautions should be taken in humid atmospheres to prevent frost formation inside the instrument from jamming the mechanism. Occasional excursions beyond this range are possible but accuracy might be impaired. The microswitch is the limiting factor which should never exceed the limits (-) 50°C to (+) 80°C.
- Fluid Temperature: A pressure switch when connected to the process is not subjected to through flow and therefore is not fully exposed to the fluid temperature. Use of adequate length of impulse piping will greatly reduce excessive heating of the sensing element. For e.g., connection of 7.5 cm of 12 mm dia impulse piping will reduce water temperature of 100°C to 65°C at an ambient temperature of 50°C. Ask factory for temperature nomogram for different temperatures.
- Ensure that impulse pipework applies no stress on sensing element housing and use spanners to hold pressure port / housing when connections are made.
- Custom built instruments are available for special service requirements under Special Engineering Category.
- For models 204 & 208, select proper 'O' Ring material compatible with process medium.
- Accuracy figures are exclusive of test equipment tolerance on the claimed values.**
- All performance data are guaranteed to ±5%.**

**DIAPHRAGM CHEMICAL SEALS**

Diaphragm chemical seals can be provided as optional extra either direct mounted or remote with capillary and threaded/flanged connection, duly evacuated and filled with suitable filling liquid. This device permits the use of pressure switches with bellows element with viscous / aggressive fluids and permits higher process temperatures. Switching delay will happen, when pressure changes rapidly.

While ordering it is important to specify ambient and process temperatures, setpoint, maximum process pressure, relative elevation

between connection and switch head, nature of process medium and whether reactive to common filling liquids should the diaphragm seal leak into the process.

**Switching differentials for Instruments with chemical seal** — Apply a multiplication factor of 1.2 for SPDT and 1.5 for DPDT to values of Differential table.

**Chemical seals are not available in certain models and ranges and also for instruments with PB Bellows.**



# MOUNTING DIMENSIONS

## GR 201 : All RANGE CODES

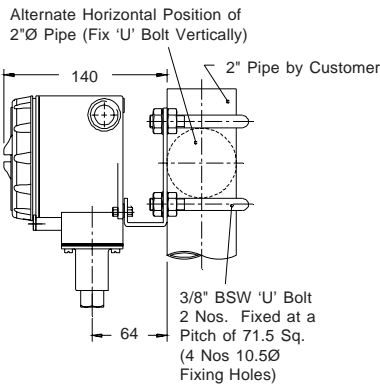
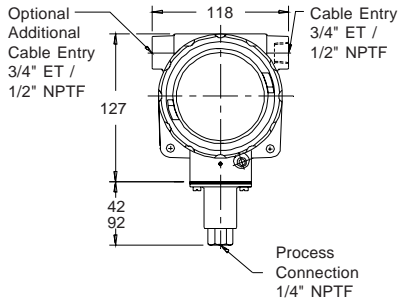

## GR S21 / S24 : ALL RANGE CODES

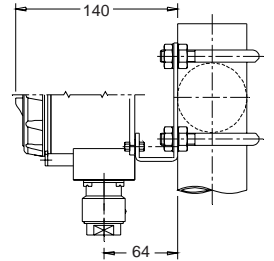
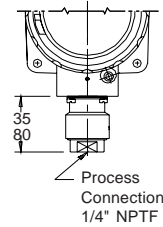

## GR 204 : All RANGE CODES

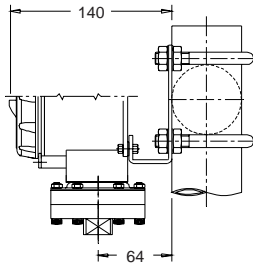
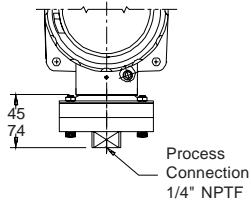

## GR 020 : ALL RANGE CODES EXCEPT F1D, A5K, G8B, A6K

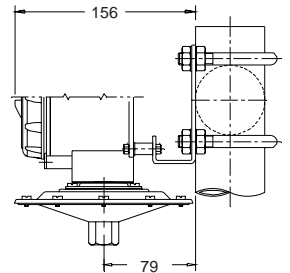
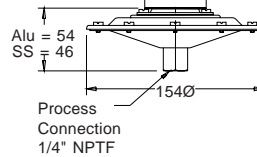

## GR 208 : All RANGE CODES

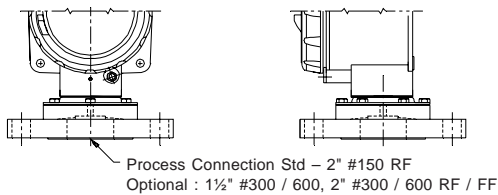

## 2" PIPE MOUNTING DETAIL

FIXING ON VERTICAL PIPE

FIXING ON HORIZONTAL PIPE

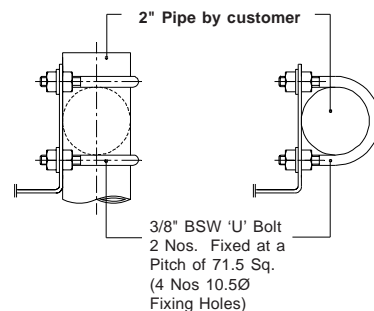

All dimensions are in mm

This is not a contractual document. Prior notification of changes in specifications is impracticable due to continuous improvement

FOR SWITZER'S OFFICES IN INDIA

CHECK AT:

<http://www.switzerinstrument.com/offices.htm>