

OPTICAL LEVEL SWITCH

SD 20

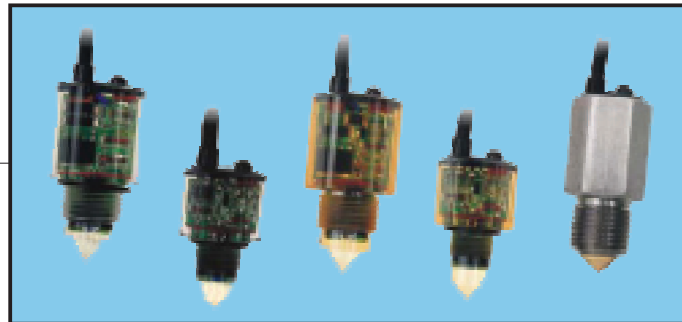

OPERATIONAL PRINCIPLE

Refraction index of plastic and air varies in big range. Infrared light can be easily reflected totally between plastic and air. In contrast, infrared light would totally penetrate through plastic while immerse in liquid. Optical switch operates by sensing the difference of refractive indices between various mediums, which causes different degree of refraction and infrared light penetration.

When dry, the transmitted light is reflected by the prism back to the receiver. When the sensor is wetted in liquid, only part of the transmitted light would be reflected back to the receiver while most is lost into the liquid. The received light then changes the signal and controls the switching accordingly. Optical switch is equipped with infrared source and receiver. They are to detect and verify the status of infrared light reflection and penetration between the mediums in order to trigger the alarm output.

PRODUCT FEATURE

- NPN, PNP open collector output to energize relay or PLC.
- Enclosure material is PC, Polysulfone, SS304 for acidity and alkaline; applicable in grease, waste water, liquid solution, liquor, alcohol...etc.
- Over-current and reverse polarity protected
- LED Status indication.

PRODUCT SPECIFICATION

Material	PC, Polysulphone or SS 304, SS316
Protection	IP68
Operation Temperature	-10 to 125°C
Ambient Temperature	-10 to 80°C
Ambient light	Max. 5000 Lux (visible light)
Operation Pressure	Max.10kg/cm2(PC,Polysulfone) Max.40kg/cm2(SS 304/316)
Power Supply	10 to 28 Vdc
Load Current	Max. Load 100mA
Overload Current Protection	100mA
Connection Thread	M12 x 1 or 3/8"BSPM 3/8" NPTM (SS304, SS316 only) 1/2" BSPM (SD204BR□□-A only)
Lead Wire	2m CABLE(dia. 3.8) 3C PVC 22 AWG; custom made if over 2m

PRODUCT DIMENSION

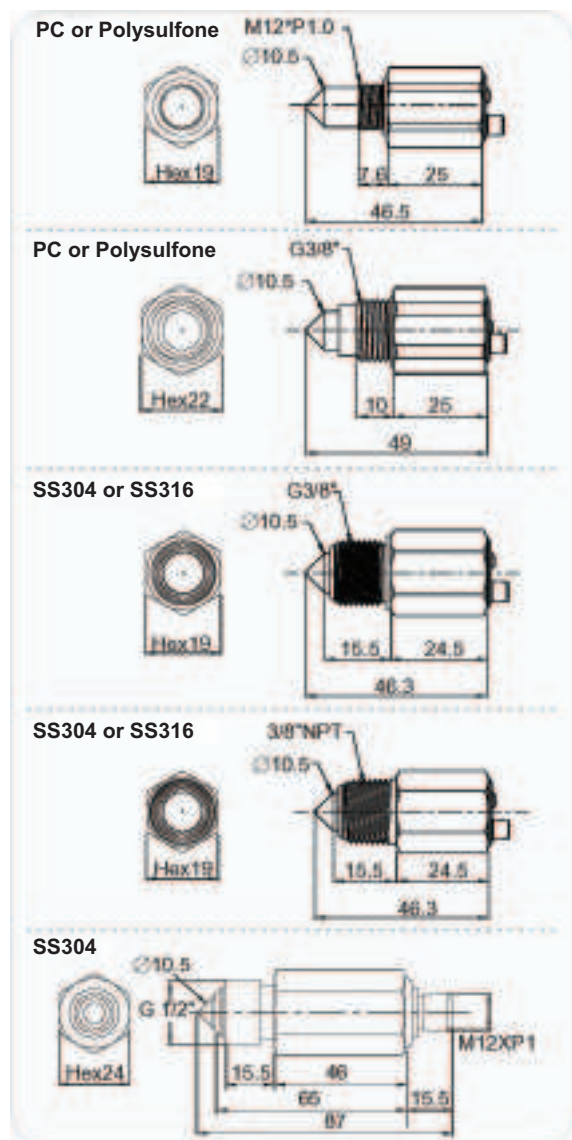



WIRING

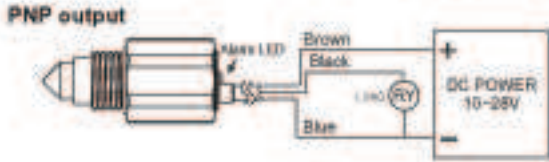
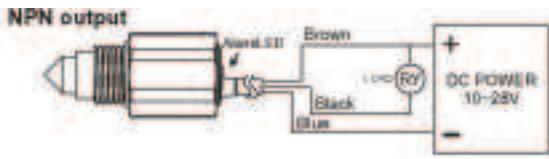

ASI

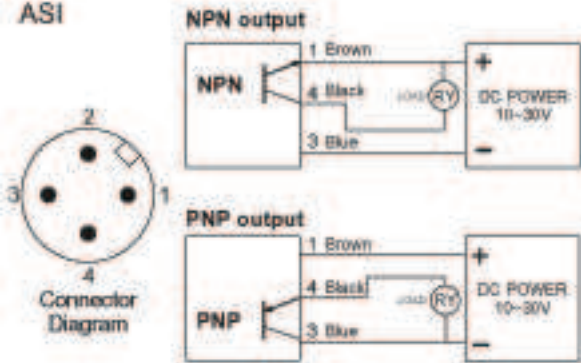

Fig.3

APPLICATION EXAMPLE

Liquid Level Control:

In Fig.4(a), two optical switches are installed individually in upper and lower level of the tank. When liquid rises to cover the upper optical switch, it will stop fill in liquid. When liquid drops down and lower optical switch is not covered by liquid, it will start filling up. Liquid has to be maintained in between upper and lower optical switches.

Motor Protection:

In Fig.4(b), optical switch is installed in lower level of the tank to prevent pump burning caused by the absence of water/liquid.

- ★ Do not install it near the corner.
Refer to Fig.4 for installation method.

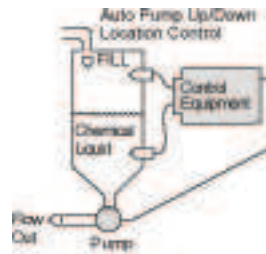

Fig 4(a)

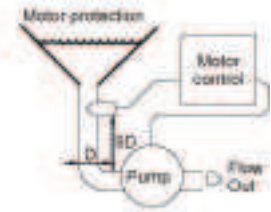

Fig 4(b)

Order Matrix

SD20 □ □ □ (-A)

Housing Material

P : PC G : Polysulfone 4 : SS304 6 : SS316

Connection Thread

M2 : M12 ×1.0 (PC, Polysulfone)
 AU : 3/8" NPT (SS 304, 316)
 AR : 3/8" BSPM
 BR : 1/2" BSPM (For SD204-BR-__-A only)

Output Form

P0 : PNP NC P1 : PNP NO
 N0 : NPN NC N1 : NPN NO

Notes : NO – Sensor tip in liquid
 NC – Sensor tip out of liquid

Connection

A : ASI

Product from FineTek

This is not a contractual document. Prior notification of changes in specifications is impracticable due to continuous improvement

FOR **SWITZER'S** OFFICES IN INDIA

CHECK AT:

<http://www.switzerinstrument.com/offices.htm>