

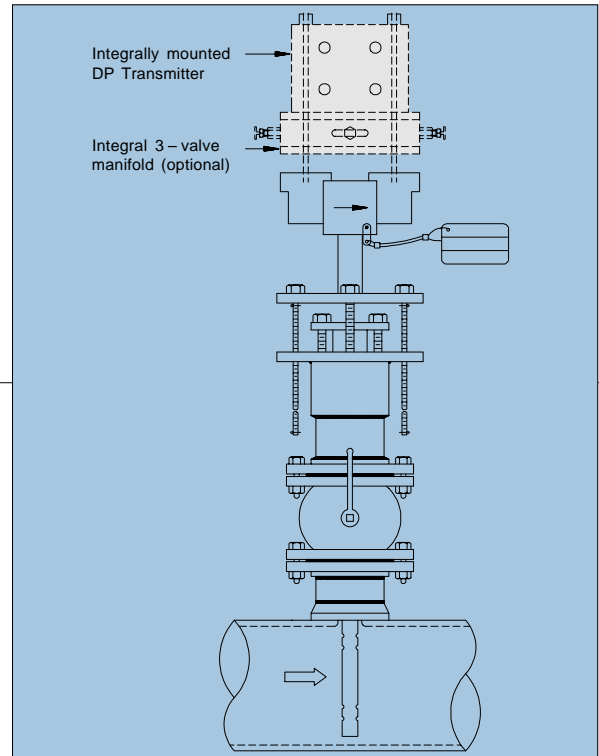

# DELTA TUBE — FLOW RATE SENSOR

323

- GAS, LIQUID AND STEAM APPLICATIONS ● RETRACTABLE TYPE (FLANGED CONNECTION) FOR INSERTION AND REMOVAL WITHOUT PROCESS SHUT DOWN ●
- LOW PERMANENT PRESSURE LOSS ● HIGH ENERGY CONSERVATION ●

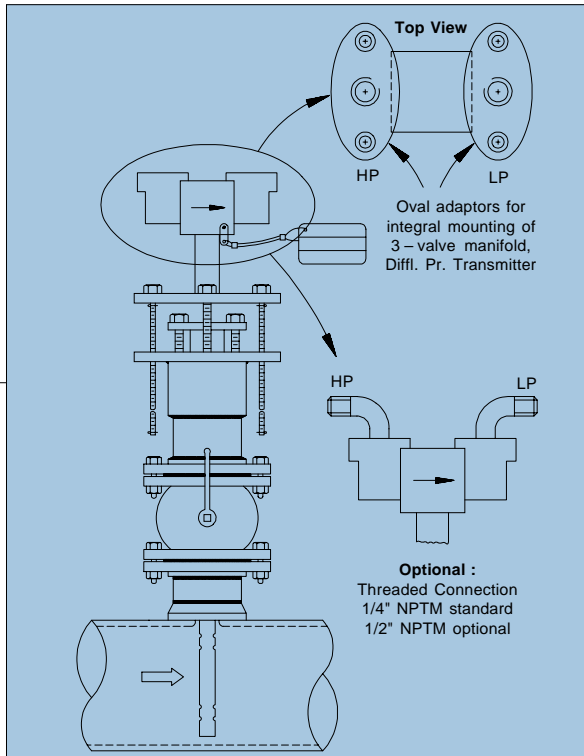

MODEL 323

The Delta tube® is a low cost, low maintenance, high accuracy flow sensor for use on steam, gas and liquid flow applications. Manufactured based on proven design of Mid-West, USA, these are rugged in construction, and simple to install. The flow sensor is a multi-ported averaging pitot tube which spans the entire flow profile and produces differential pressure which has square root relationship with flow rate. Based on pipe or duct size the Delta tube is constructed so that strategically located sensing ports continually sample the impact and static pressures produced by the Delta tube's obstruction of the flow stream profile. Within the probe the impact pressures sensed by the upstream are continually averaged in an isolated plenum chamber. Similarly the static pressures sensed by the downstream ports are averaged in a second isolated plenum chamber.

All conventional secondary instruments can be used for direct measurement, or transmission of the differential pressure produced by the Delta tube which is proportional to square of flow rate.

The model 323 is a wet tap type Delta tube with retractable facility having flanged connections so that

these can be directly welded on to the weld-o-let provided on the pipe. This Delta tube can be inserted or retracted without process shutdown. These are suitable for line sizes ranging from 14" to a maximum of 72" as standard. For higher line sizes please consult factory. Material of construction for probe is 316 SS as standard. Attaching hardware can be of either CS or 316 SS.

Many other versions of Delta Tubes are also available to suit various applications such as in-line series, direct insert type, flange mounted type, duct mounted type or wet tap type with threaded connection having retractable facility vide models 300, 301, 302, 341, 342, 343, 307, 308, 311, 321, 331, 312, 322 and 332.

Delta Tubes offer excellent advantages compared to conventional primary flow elements such as — low installation cost, low permanent pressure loss and hence high energy conservation.

The process connection head of the delta tube has been designed to facilitate integral mounting of a 3-valve manifold and so the transmitter as well. Please refer schematic diagram shown above.

## GENERAL SPECIFICATIONS

<b>Basic Model No.</b>	323
<b>Design</b>	Mid-West, Michigan USA
<b>Mounting Type</b>	Delta tap — insertion and removal with insert retractable facility without process shutdown (flanged connection).
<b>Probe Details</b>	
<b>Profile</b>	Circular
<b>Size</b>	2¼" dia.
<b>Material</b>	316 SS
<b>Pressure and Temperature Rating</b>	} 300 PSIG at 40°C (for both CS and 316 SS attaching hardware)
<b>Support</b>	
<b>Process Connection</b>	<b>Standard</b> : Oval adaptors for integral mounting of 3 – valve manifold and / or Differential Pressure Transmitter. <b>Optional</b> : Threaded connection 1/4" NPTM std; 1/2" NPTM optional.

### Attaching Hardware Details

<b>For Top Support</b>	
<b>Weld-o-let</b>	CS or 316 SS to suit probe dia
<b>Weld nipple, extension nipple, weld neck flange &amp; packing gland</b>	To suit probe dia
<b>Packing</b>	Solid teflon or Grafoil rings
<b>Insert Retract Mechanism</b>	Provided in 316 SS
<b>Insertion Valve Details</b>	
<b>Type</b>	Ball valve
<b>Body Material</b>	CS or 316 SS
<b>Trim Material</b>	316 SS
<b>Rating</b>	Limited to flange rating
<b>Valve Connection</b>	3" ANSI 150 RF
<b>For Bottom Support</b>	
<b>Thread-o-let</b>	CS or 316 SS, 1" NPTF
<b>Pipe Plug</b>	CS or 316 SS, 1" NPTM
<b>Accuracy</b>	±1% of actual flow

### PROBE CONSTRUCTION AND PROFILE

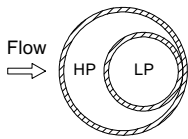

#### “Tube – Inside – Tube” Circular Profile

Delta Tube Size : 2¼"  
Applicable for Model : 323

## ORDERING INFORMATION

<b>BASIC MODEL NO.</b>	323	<b>A</b>	<b>N</b>	<b>0</b>	<b>0</b>	<b>H</b>	<b>A</b>
<b>ATTACHING HARDWARE MATERIAL</b>		<b>A</b>					
Carbon Steel (Standard)		<b>A</b>					
All 316 Stainless Steel		<b>B</b>					
<b>PIPE SIZE</b>							
14" <b>N</b>	24" <b>S</b>	48" <b>W</b>					
16" <b>P</b>	30" <b>T</b>	60" <b>X</b>					
18" <b>Q</b>	36" <b>U</b>	72" <b>Y</b>					
20" <b>R</b>	42" <b>V</b>	Special <b>Z</b>					
<b>PIPE SCHEDULE</b>							
Schedule 40						<b>0</b>	
Schedule 80						<b>1</b>	
All others including Cast Iron Pipe, Concrete lined, Fibreglass, etc., (Customer to specify)						<b>9</b>	
<b>CONSTRUCTION</b>							
Single support							<b>0</b>
Double support							<b>1</b>
For duct installation with single support							<b>2</b>
For duct installation with double support							<b>3</b>
<b>PROCESS PIPE ORIENTATION *</b>							
Horizontal							<b>H</b>
Vertical							<b>V</b>
<b>SEAL MATERIAL</b>							
Solid Teflon® (Standard)							<b>A</b>
Grafoil®							<b>B</b>
Special (contact factory)							<b>Z</b>

**Note** : \* Generally the Probe Orientation is Vertical in the process line. If it is different, customer to specify clearly with a sketch.  
**For more technical information on theory, sizing, selection, installation, etc., please ask switzer brochure on “Delta Tube Flow Elements”.**

\* Teflon® is a registered trademark of E.I.Dupont de Nemours and Company  
Grafoil® is a registered trademark of UCAR Carbon Co. Inc

**Prior notification of changes in specification is impracticable due to continuous development.**

FOR **SWITZER'S** OFFICES IN INDIA

CHECK AT:

<http://www.switzerinstrument.com/offices.htm>

Manufactured with  
Know-how from  
**Mid-West®**  
Instrument  
MICHIGAN, USA