



MODEL 711

ELECTRONIC PRESSURE SWITCH

OPERATION AND INSTRUCTION MANUAL



Switzer Instrument Limited

Regd. Off: 29 (Old# 14), Thanikachalam Road, P.B.No.1423, Chennai 600 017

Internet web-site
www.switzerinstrument.com

Sales – Head Office

17 (Old# 9), South Boag Road, Chennai 600 017

Ph : 044-24340999 / 24343956 / 24344321

Fax : 044-24347887 e-mail : sales@switzerinstrument.com

Works

127 SIDCO North Phase, Ambattur Ind Estate, Chennai 600 098

Ph : 044- 26242255 / 26243355

Fax : 044-26248849 e-mail : works@switzerinstrument.com

INTRODUCTION

SWITZER Model 711 Electronic Pressure Switch is a versatile instrument which can continuously measure, display and control process pressure.

The sensor's piezo-resistive stainless steel element which can be used for most of applications. The process pressure is displayed through an 8 character dot matrix LCD that can display both numerals and alphabets. The appropriate engineering units can be selected from the menu and displayed as required.

The instrument is provided with two on-off control relays with independent set point, dead band and time delay settings possible through 3 front accessible keys. The instrument is also provided with an analog 4-20 mA current output. Status indicating LEDs are provided for each set point relay.

The instrument requires an operating power of 20 to 30V DC.

The instrument electronics is housed in a weather proof enclosure complying to IP65.

PRINCIPLE OF OPERATION

The basic principle of operation is described below. Refer to Fig-1 for the functional block diagram which shows the various elements of this instrument.

The primary pressure sensing element for the detection is a stainless steel diaphragm on which piezo-resistive elements are configured in a bridge form.

When the diaphragm is subjected to a pressure, the stress produces a strain on the deposited bridge to give an electrical output when excited. The sensor is temperature compensated to ensure minimal drift with ambient and process temperature changes.

The sensor output signal is suitably conditioned to generate the necessary signal and is fed to a A-to-D convertor to convert it to digital signal compatible to a micro-controller.

This digital signal is processed to provide output for process pressure display on LCD, output to relay for on-off control and output as 4-20mA analog current.

Fig-1: Functional Block Diagram

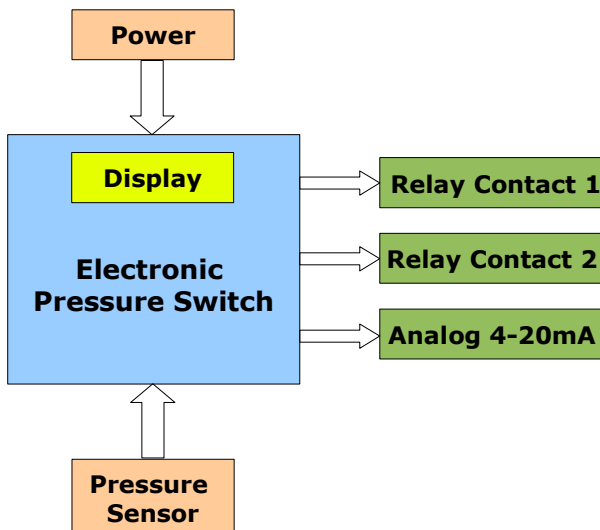

Fig-2a: Overall Dimension – Front View

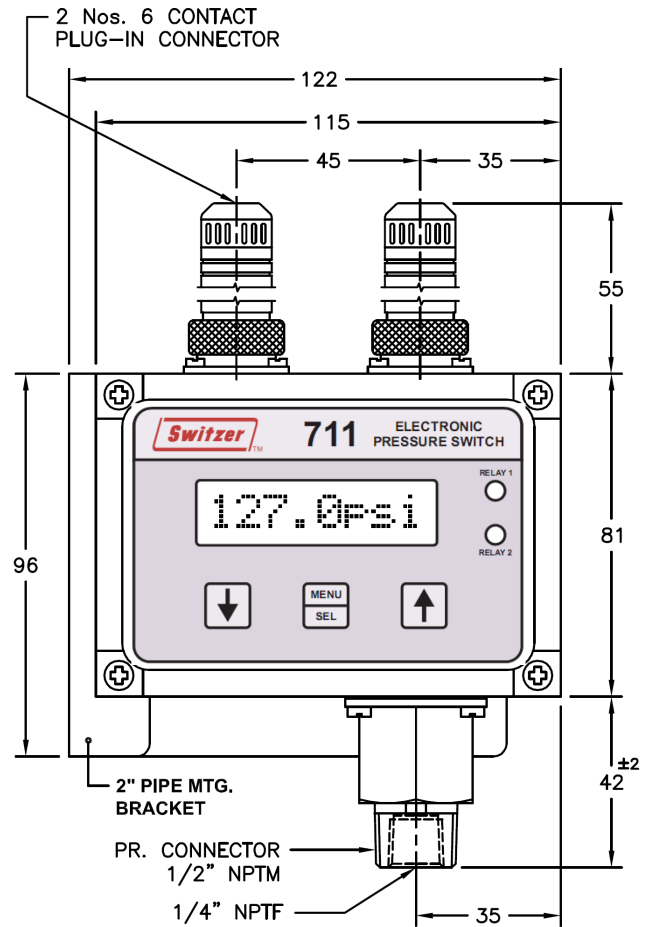
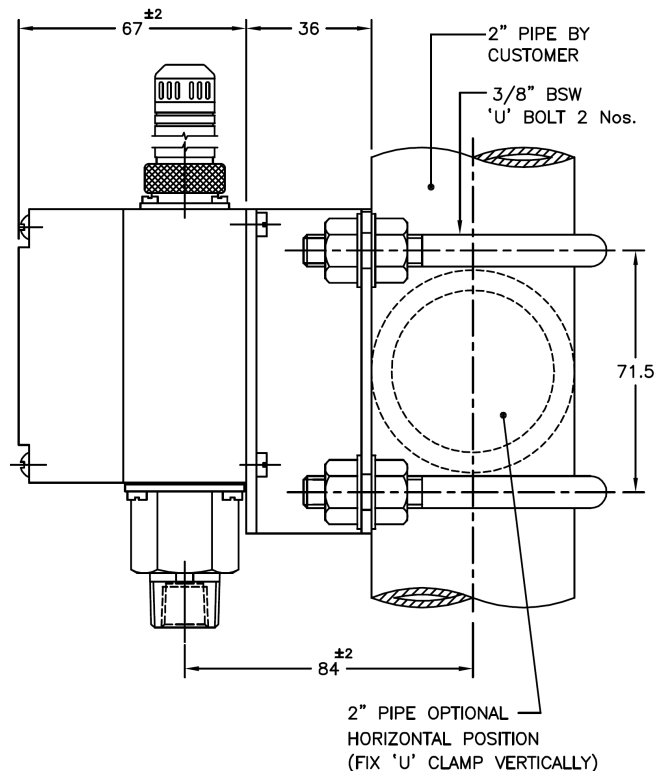

Fig-2b: Overall Dimension – Side View



INSTALLATION INSTRUCTIONS

Model 711 Electronic Pressure Switch can be installed on to a process line through 2 methods as mentioned below.

The default process connection provided in the instrument is 1/2"NPT(F) and 1/4"NPT(M) connection and the process pressure line is to have suitable mating connector for this thread. If the pressure connection is other than what is mentioned above, use a suitable adapter to install the instrument.

1. Direct online mounting:

The instrument is mounted directly on to the process pressure line in which pressure is to be measured.

2. Pipe mounting:

The instrument is mounted on a 2" pipe with suitable brackets and u-clamp which are provided along with the instrument.

Use a 28mm A/F wrench at the hexagonal area above the process connection thread to fix the transmitter onto a pressure line.

See Fig-2a & 2b for overall dimension in front view and side view. Fig-2b also shows the 2" pipe mounting arrangement for both vertical and horizontal pipe positions.

CAUTION

1. Do not use the instrument body to hold and rotate it when installing in the process line. This may damage the sensor mounting arrangement and the internal sensor electrical connection.
2. Do not use excessive force to lock the electrical cable connector with the chassis mounted connector. This may damage the lock ring resulting in loose and improper electrical connection.
3. Electrical cable connector has to be securely tightened with mating connector on the instrument to ensure proper IP65 weatherproof compliance.
4. Ensure that the top cover is fixed firmly with the bottom housing with the cover screws for proper IP65 weatherproof compliance.
5. Ensure the body of the instrument is electrically earthed at the location marked with Earth symbol. This is for the safety of the instrument and personnel.

ELECTRICAL CONNECTION AND WIRING

The electrical connection for the instrument is provided through two plug-in polarized circular connectors with locking arrangement and are located on the top side of the housing.

The connector on the left side, when viewed from the front, is for Power and Analog Current output.

The connector on the right side is for Relay Contact output.

Each of the connectors have 6 pin for electrical connections. Use a 6 core cable, with each core of 20 AWG (0.5 sq.mm) wire. The overall OD of the cable shall not exceed 8.0 mm for proper weatherproof compliance.

Cable wiring:

The connector pin arrangement is shown in Fig-3 which is the male connector mounted on the housing when viewed from the top with the display on front. The number '1' marked on the connector insulator indicates the pin identifier for first pin. The attached line in anti-clockwise direction to each pin shows the successive pins starting from the first pin which ends at pin 8.

Fig-3: Connector pin arrangement

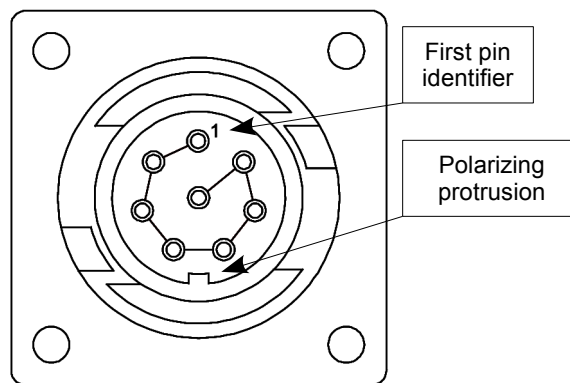

Both the connector contains 6 pins which can be wired for electrical connection and 2 locations are left blank without pins. These are not identical connectors as different set of 6 pin positions are used for electrical connection. The connectors cannot be interchanged for electrical connection.

Below are the connection arrangement of each of the connectors.

Table-1: Electrical connection arrangement

Pin position	Left connector POWER and ANALOG OUTPUT	Right connector RELAY 1 & 2 CONTACT OUTPUT
1	NO CONNECTION	BLANK – No pin
2	POWER V+	RELAY 1 – NO
3	POWER V-	RELAY 1 – COM
4	BLANK – No pin	RELAY 1 – NC
5	BLANK – No pin	RELAY 2 – NC
6	4-20 mA -	RELAY 2 – COM
7	4-20 mA +	RELAY 2 – NO
8	EARTH	BLANK – No pin

Cable assembly:

Follow the below procedure for cable wiring and assembly with the connector.

1. Disassemble the female connector into separate elements which are boot, gripper and hood.
2. Insert the cable end into the hood, gripper and boot as shown in Fig-4.
3. Remove the outer insulation and also from each core.
4. Solder the wires into respective pins of connector. Ensure that there are no solder or wire shorts.
5. Push the boot, gripper as close as possible towards the connector pins and screw the hood on to the female connector threading to firmly hold the cable. Proper tightening of this also ensures weatherproof compliance.

6. This completes the wiring.
7. Insert the wired cable connector into the mating connector on the instrument housing and rotate the locking outer ring clockwise to lock the connector. Refer to Fig-5 for details.

Fig-4: Cable assembly

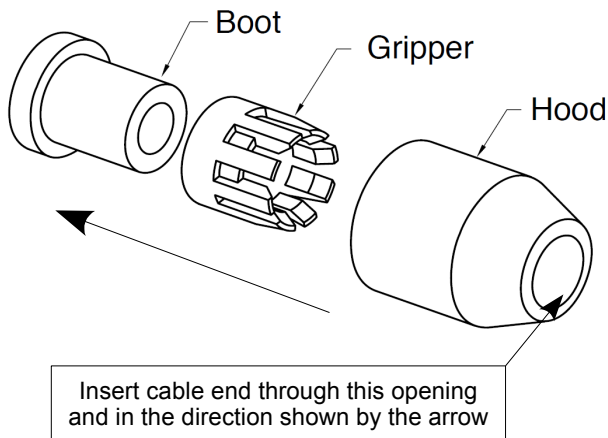
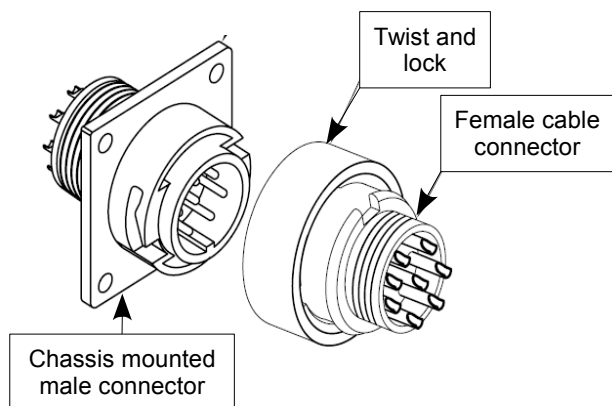

Fig-5: Connector locking arrangement



FUNCTIONAL BLOCKS

Refer to Fig-6 for instrument front view with all parts shown.

Display:

The instrument is provided with a large 8 character dot matrix LCD to display process pressure, engineering units and other menu/commands related to programming.

The process pressure value is displayed with 5 characters comprising 4 characters for numerals and 1 character for decimal point. The engineering units are displayed with 3 characters as alphabets.

The decimal point position is fixed automatically based on the calibrated range and selected units. The decimal point position cannot be altered by the user. Various ranges offered and the applicable maximum display values with decimal point position for respective units are shown in Table-2.

This LCD has a back-light feature to enable easy readability and there is an option to select it as permanently on or auto off mode after entering into the programming mode.

User keypad:

The instrument is provided with a front access membrane

keypad with 3 keys for all functional settings and programming. These are UP, DOWN & MENU/SELECT.

Table-2: Pressure range with applicable display values

Range	Bar	PSI	KSC	KPa	MPa
1	1.000	14.50	1.020	100.0	N/A
2	2.000	29.01	2.039	200.0	N/A
3.5	3.500	50.76	3.568	350.0	N/A
10	10.00	145.0	10.20	1000	N/A
20	20.00	290.1	20.39	2000	N/A
35	35.00	507.6	35.68	N/A	3.500
100	100.0	1450	102.0	N/A	10.00
200	200.0	2901	203.9	N/A	20.00
350	350.0	5076	356.8	N/A	35.00

Note: "N/A" in the above table indicates that those units are not displayed for the indicated ranges as those are too high or too low a value and may.

Units:

User has the option of selecting any of the following units through the front membrane key pad buttons. The units are displayed with 3 characters. The default unit is Bar.

- Bar
- PSI
- Kg/Sq.cm (displayed as KSC)
- KPa
- MPa

Relay:

The instrument is provided with 2 relays for on-off control function. Each of the relays can be programmed with independent settings for operation after entering into the specific relay loop in menu.

The various parameters that can be programmed are as below.

RL1 ON & RL2 ON: This is the pressure value at which the relay comes on. This can be set independently for relay 1 and 2.

RL1 OFF & RL2 OFF: This is the pressure value at which the relay goes off. This can be set independently for relay 1 and 2.

The relay on and off values can be set anywhere within the calibrated instrument range. The difference between these on and off values automatically becomes the hysteresis (dead band).

For example, let us assume the following conditions.
Relay-1 ON value is 30.0 bar and OFF value is 31.0 bar.

When pressure rises from 0.0 bar pressure, Relay-1 will be ON till it reaches 31.0 bar and goes OFF at 31.0 bar. This will remain OFF for any pressure higher than 31.0 bar.

During falling pressure from a higher pressure value, the relay will come ON only at 30.0 bar and will remain ON for pressure values below 30.0 bar. The same status as described above repeats for increasing and decreasing pressure.

Time delay: This is the time in secs which makes the relay come on after a delay. The maximum time delay that can be set is 250 secs. This delay is applicable only when the relay

comes ON and no time delay can be set for relay OFF function. This can be set independently for relay 1 & 2.

Status LED:

Relay-1 and Relay-2 operating status are indicated by 2 LEDs which are visible from front of the instrument.

- OFF LED indicates Relay off.
- ON LED indicates Relay on.
- FLASHING LED indicates time delay process in progress. LED will flash only if relay time delay is set to a value of 1 or more secs.

Analog Output:

The instrument is provided with a 4-20mA analog current output corresponding to the instrument calibrated full scale range. This current output cannot be re-calibrated for smaller ranges within the calibrated full scale range.

At Zero pressure input, analog current output is 4mA.
At Full Scale pressure input, analog current output is 20mA.

POWER ON SEQUENCE:

When the instrument is powered on, following information appears on the display in this sequence and each of these will last for about 3 secs. Finally the pressure as measured by the sensor will appear with selected units.

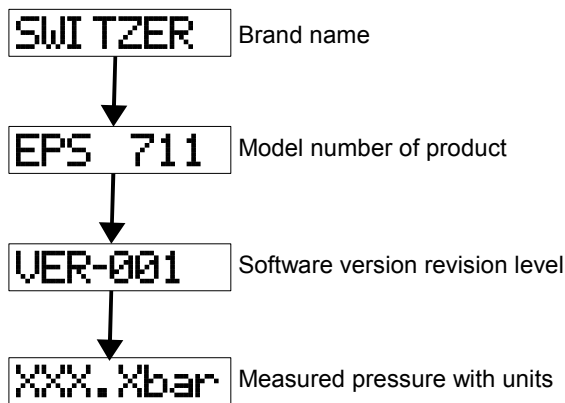

PROGRAMMING MODE

Programming of the instrument is done through 3 push button keys available on the front membrane keypad. The 3 keys are UP (↑), DOWN (↓) and MENU/SELECT.

UP: This is used for incrementing any numerical value or moving to the next higher step in the programming menu.

DOWN: This is used for decrementing any numerical value or moving to the next lower step in the programming menu.

MENU/SELECT: This is used for selecting a function or a step and confirming it so that the selected function/step is stored into the memory for continuous operation.

Unit selection:

The default unit selected is bar. This default unit can be changed to the required units in 2 ways – without entering the menu (or) by entering into the menu.

The procedure for changing the units without entering the menu is provided in this section. Procedure for changing the units after entering into the menu is provided in the subsequent sections.

The units can be changed when the display is showing the

actual process pressure. Press UP or DOWN key to change the units by advancing to the next unit or selecting the preceding unit. Continuous pressing of the UP or DOWN key will keep changing the units successively without stop and will also roll over to the .

Changing the units during the normal functionality of the instrument will not affect the measurement or the control function. Once the unit is changed, it will also change all other parameters like relay on and off values automatically to the new selected units.

The below example shows the full scale display value with various units corresponding to an instrument calibrated with a 10 bar sensor.

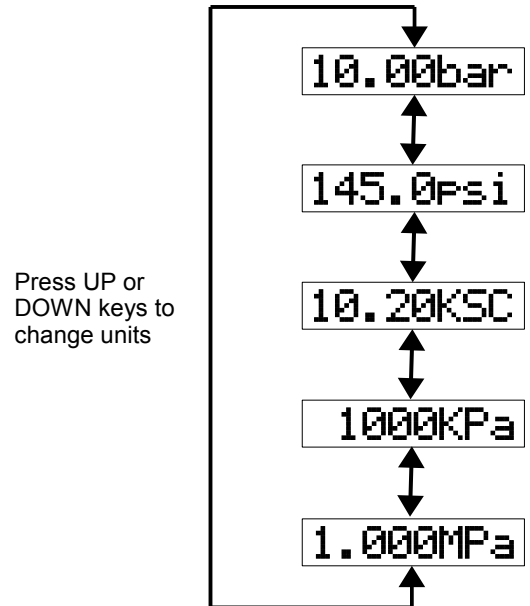

Menu functions:

Values for following parameters are set/selected after entering into into the main menu.

- Units
- Relay
- Backlight
- Information
- Exit

Press MENU/SELECT key to enter into menu mode. The first function to appear on display is UNITS.

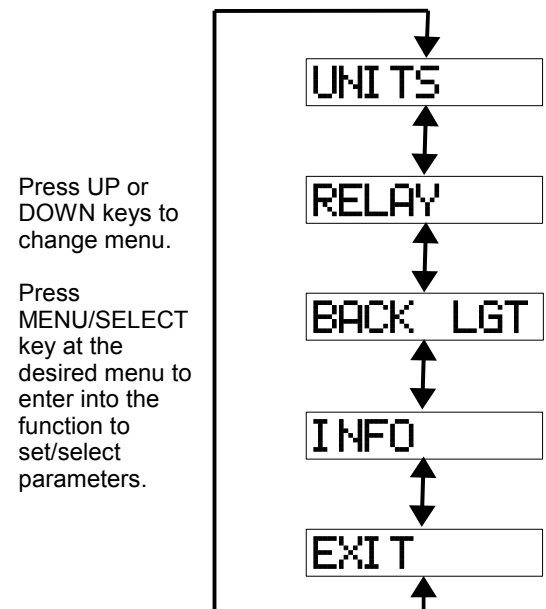

Pressing UP and DOWN keys will scroll through the successive main menu functions.

Press MENU/SELECT key at the desired menu function to enter into that function to set/select its parameters or exit to the normal pressure display mode.

Note: After entering into the menu, if no key is pressed for about 30 mins, the display automatically exits to the measurement mode and will display process pressure.

Units:

This is another method to select the units.

Press MENU/SELECT key after selecting UNITS in the main menu. The first units to appear on display will be "bar".

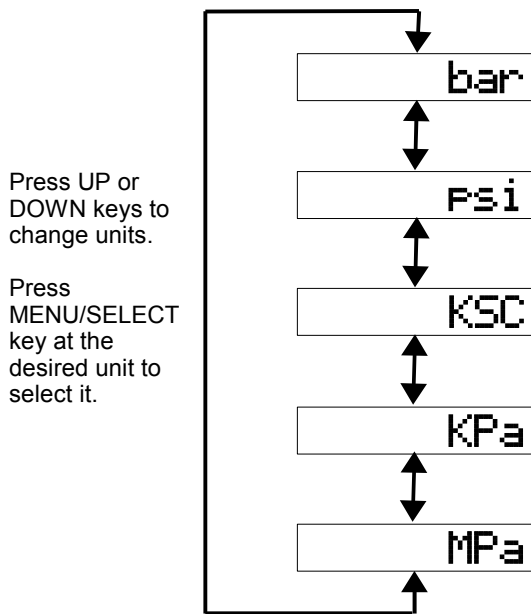

After selecting the required units, the display will revert back to main menu and will display UNITS.

Scroll to the next menu function.

Relay:

All parameters for Relay-1 and Relay-2 are set in this menu.

Press MENU/SELECT key after selecting RELAY in the main menu. The display will show "RELAY 1".

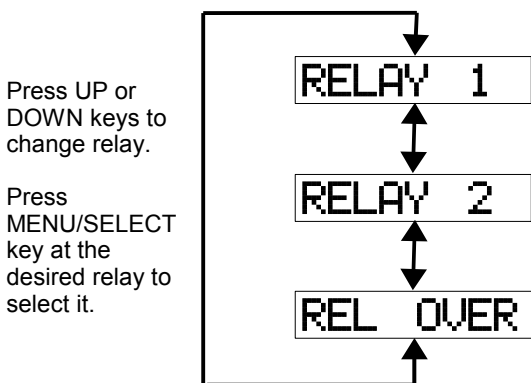

Relay-1:

All Relay-1 parameters are set in this sub menu.

Press MENU/SELECT key after selecting RELAY 1 in the relay sub menu. The display will show "RL1 ON".

Press UP or DOWN keys to change Relay-1 functions.

Press MENU/SELECT key at the desired Relay-1 function to set/select parameters.

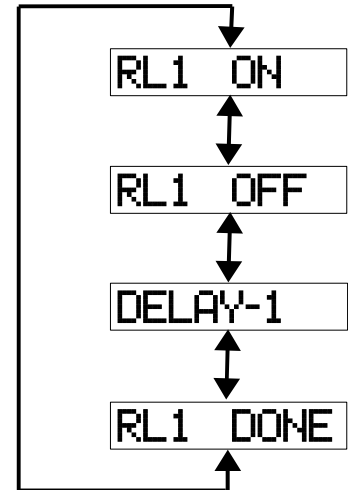

Press MENU/SELECT key after selecting RL1 ON to set Relay-1 ON value.

Use UP or DOWN keys to increment or decrement Relay-1 ON value.

Press MENU/SELECT key to confirm Relay-1 ON value.

Display will now indicate RL1 OFF.

Press MENU/SELECT key to set Relay-1 OFF value.

Use UP or DOWN keys to increment or decrement Relay-1 OFF value.

Press MENU/SELECT key to confirm Relay-1 OFF value.

Display will now indicate DELAY-1.

Press MENU/SELECT key to set Relay-1 time delay value.

Use UP or DOWN keys to increment or decrement the Relay-1 time delay value in seconds. Maximum of 250 secs can be set. If there is no delay required set 0 secs.

Press MENU/SELECT key to confirm Relay-1 time delay value.

Display will now indicate RL1 DONE.

Press MENU/SELECT key to confirm Relay-1 settings.

Display will now indicate RELAY 2.

Relay-2:

All Relay-2 parameters are set in this sub menu.

Follow the same process as mentioned above for Relay-1 to set the parameters for Relay-2. The display will show RL2 and DELAY-2 corresponding to Relay-2.

After setting all parameters for Relay-2 by the above procedure, display will now indicate RL2 DONE.

Press MENU/SELECT key to confirm Relay-2 settings.

Display will now indicate REL OVER.

Pressing MENU/SELECT will confirm the settings for relay and the display will revert back to main menu and will display RELAY.

Scroll to the next menu function.

Back-light:

The display back-light operational status is set here. This is displayed as "BACK LGT". There are 2 modes -

Back-light ON:

In this mode, back-light is continuously ON.

Back-light AUTO OFF:

In this mode, the back-light goes off after about 15 secs after any key is pressed. The back-light comes ON immediately when any key is pressed.

Press MENU/SELECT key after selecting BACK LGT in the main menu. The display will show "AUTO-OFF".

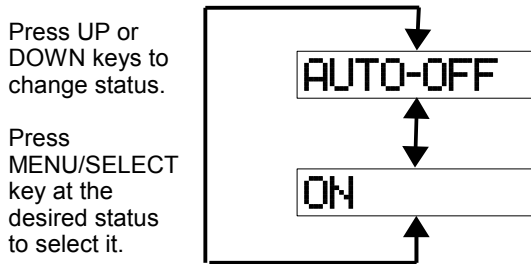

After selecting the required back-light status, the display will revert back to main menu and will display the next function INFO.

Info:

This function enables the user to view all the set parameters without going into each of the functions like units and relay. The set parameters are displayed successively one after another. Each of the parameters will appear on display for about 2-3 secs.

Press MENU/SELECT key after selecting INFO in the main menu. The display will show the below parameters on display.

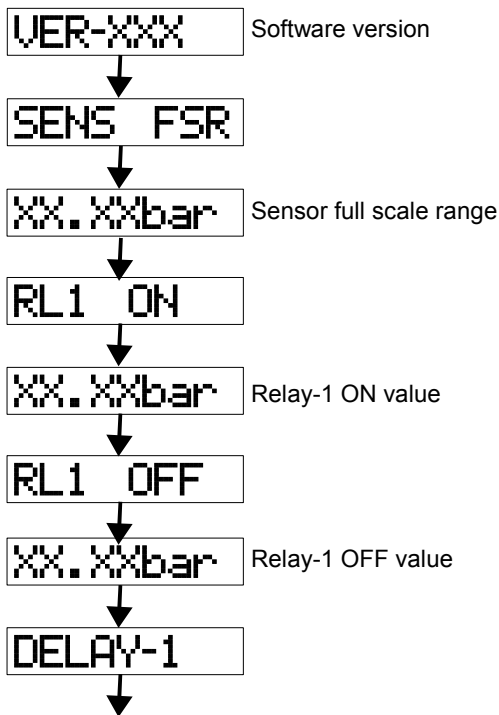

Contd. In next column

Contd. from previous column

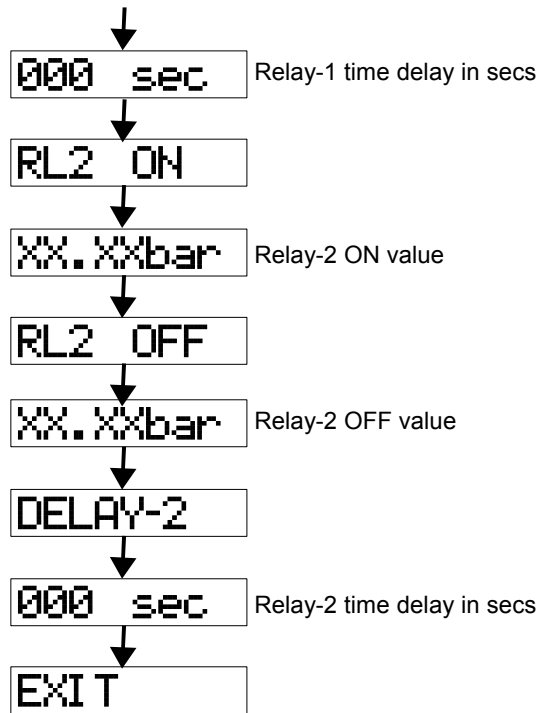

The display will show EXIT at the last after all the above successive parameters are displayed.

Exit:

Press MENU/SELECT key with EXIT on display will allow the instrument to exit out of the programming mode and will enter into the measurement mode and will display the measured process pressure.

This completes all setting of parameters and programming.

Fig-6: Instrument front view

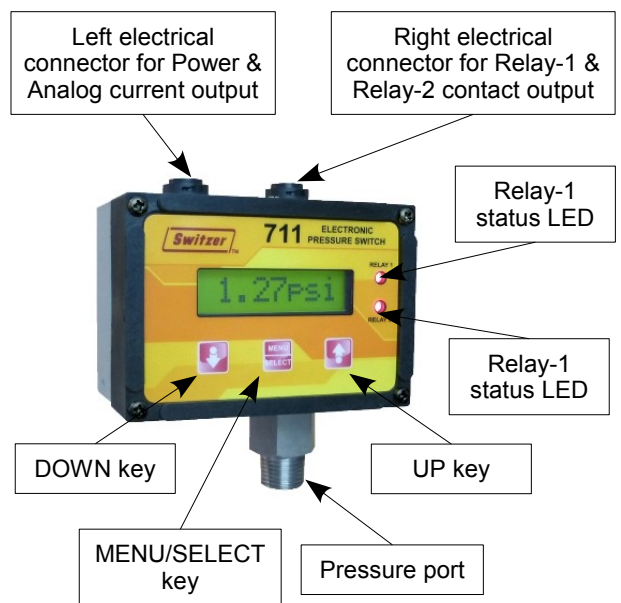

TECHNICAL SPECIFICATIONS

Characteristics	Specifications
ELECTRICAL	
Model	711 Electronic Pressure Switch
Sensor	Piezo-resistive SS316 pressure sensor
Range	0 to 1, 2, 3.5, 10, 20, 35, 100, 200, 350
Accuracy	±0.3% of FSR
Max. pressure	2x of FSR
Power	DC: 20 to 30 V, fully isolated, 3W max.
Electrical Connection	<p>Option - C: 2 Connectors – 6 pin circular polarized with locking arrangement.</p> <p>Option - F: 2 Connectors as above with 2 mtrs cable of 6 core, each core of 20 AWG (0.5mm²) and maximum OD of 8mm.</p>
DISPLAY	
Display	1 x 8 dot matrix LCD with yellow green back light
Display character height	10.7 mm
Process value	4 digits, 9999 counts maximum
Decimal point	Automatically selected based on engineering units
Display units option	5 units – bar, psi, Kg/cm ² (KSC), KPa, MPa.
ANALOG OUTPUT	
Analog output	Current 4-20 mA
Analog output range	Same as instrument calibrated range
Load capacity	400 ohms
RELAY CONTACT OUTPUT	
Set points	2
Set point range	0 to 9999 counts
Relay contact rating	2 independent relay contacts, each with following ratings 5A at 250V AC / 28 VDC @ 30°C ambient 3A at 250V AC / 28 VDC @ 60°C ambient
Time delay	0 to 250 secs adjustable
Relay status	Relay ON indication by red LEDs for each set point
Dead band	1 to 9999 counts – fully configurable through Relay ON and OFF setting
MECHANICAL	
Enclosure protection	Die-cast Aluminium Weatherproof to IP: 65

Characteristics	Specifications
Process connection	1/2" NPTM & 1/4" NPTF, others through adapter
Process connection material	SS316
Wetted parts	316SS, NBR/Viton
Mounting	Direct on line or 2" pipe
Overall dimension	Front bezel: 115(w) x 81(h) Overall size: 115(w) x 178(h) x 67(d)
Approximate weight	680 gms
Process temperature limits	-40°C to 120°C
Ambient temperature limits	0 to 60°C
Ambient relative humidity	95.00%