



MODEL K-5711 / K-5712

**R.F.CAPACITANCE LEVEL SWITCH
SINGLE / DUAL POINT**

OPERATION

AND

INSTRUCTION MANUAL



Switzer Instrument Limited

Regd. Off: 29 (Old# 14), Thanikachalam Road, P.B.No.1423, Chennai 600 017

Internet web-site
www.switzerinstrument.com

Sales – Head Office

17 (Old# 9), South Boag Road, Chennai 600 017

Ph : 044-24340999 / 24343956 / 24344321

Fax : 044-24347887 e-mail : sales@switzerinstrument.com

Works

127 Sidco Estates, Chennai 600 098

Ph : 044-26242244 / 26242255 / 26243355

Fax : 044-26248849 e-mail : works@switzerinstrument.com

INTRODUCTION

SWITZER Model K-5711/5712 R.F. Capacitance Single/Dual Point Level Switch has been developed for monitoring and control of a wide range of liquid and bulk material level.

The electronics are housed in a weather proof and flame proof enclosure to be used for non-hazardous and hazardous area applications. Two types of instrument mounting arrangement are possible depending on the user requirements – Integral mount or Remote mount. The Integral mount version will have the control electronics and probe together as a single instrument directly mounted on the tank. The remote version will have a separate probe unit, which is mounted on the tank and a separate remote mount control electronics.

The instrument is powered with either 90 to 250VAC or 18 to 32VDC, which need to be selected based on the ordering information.

Necessary status indicating lamps are provided to indicate Power On, Relay status and Material Presence status.

The K-5712 dual setpoint model can also be configured to operate as a wide differential model which is commonly used for pump on-off control to fill or empty industrial tanks.

PRINCIPLE OF OPERATION

The amount of capacitance developed between probe and vessel is dependent on:

1. Surface area of the probe
2. Distance between probe and vessel or ground reference
3. Di-electric constant of the process medium

Since the mounting position of the probe is fixed and di-electric value of the medium is also fixed, the capacitance developed between the probe and ground reference increases and decreases as the medium rises and falls in the tank. The capacitance range can be varied by selecting different probe diameter, length and its proximity to the wall (ground reference).

The capacitance change between the probe and ground reference is converted to variable frequency pulses which is signal conditioned to initiate the on-off control circuit and the relay.

In remote mount version, the pulse transmitter circuitry is mounted on the probe head. This circuit provides the necessary frequency pulses to the remote control circuit to activate the on-off control relay.

In integral mount version, the pulse transmitter circuitry is also fixed along with the control circuit in the same enclosure along with the level probe.

PROBE TYPES

There are 3 types of level probes used for level measurement applications.

1. Single probe
2. Dual probe
3. Stillwell probe

Single probe is used for metallic tank applications where the tank itself acts as the reference element. For certain dry solids applications, the single probe may also be provided with a guard near the process connection end. This guard is connected to the reference element and hence forms an

inactive portion.

Dual probe is used for non-metallic tank applications. Here, one of the dual probes acts as the reference element.

Stillwell probe is used for non-metallic applications and is also used for certain metallic tank applications where the signal strength is too low or tank shape is irregular or if there is excess turbulence of the media. The signal strength need to be increased for effective signal conditioning. The outer stillwell pipe acts as the reference element.

INSTALLATION INSTRUCTIONS

For Integral mount Level Switch, the probe with entire control electronics are housed in one enclosure. This is mounted directly on the tank.

For Remote mount Level Switch, the probe and the control electronics are mounted separately. The probe with pulse transmitter circuitry is mounted on the tank and the control electronics is mounted at a convenient and accessible location away from the tank.

Basically the level probes are classified as Rigid Probe and Flexible Probe. Rigid probes are used for probes with length less than 3 metre. All probes which are greater than 3 metre are of flexible wire rope. Flexible rope type level probes are mounted only vertically in the tank.

These flexible rope shall have 2 types of end configuration.

1. Counterweight: Counterweight is provided at the bottom to suspend the rope straight, for uniform signal generation.
2. Anchor: Fittings are provided on the rope tip for convenient anchoring inside the tank. This is the recommended method for all rope type probes as this will not allow the swaying of rope due to the rise and fall of media in the tank.

Probe installation:

All probes are directly mounted on the tank with one of the below process connections.

1. Screwed process connection
2. Flanged process connection

Both these connections are applicable for all types of probes described in the previous section.

Metal tanks:

It is common practice to use the metal tank wall as the ground reference for Single probes. When doing this, it is required that the probe housing with the process connection make a good electrical connection to the tank wall. If there is any doubt about this connection (due to rust, using PTFE thread tape, gaskets, paint, non-metallic process connection may impede this connection), then a separate strap should be installed between the probe housing and the tank. Connect the tank wall to Earth tag on the housing adjacent to cable entry and cover lock.

Sensing probes should be located close to the tank wall for greatest sensitivity in non-conductive media (such as diesel, kerosene, lubricating oil, etc. which has dielectric constant less than 5).

Non-metal tanks:

Dual probe or Stillwell probe is used when level instruments are installed on non-metallic tanks. The reference element is internally connected to the enclosure for establishing the necessary grounding for signal generation.

Remote electronics installation:

The remote control electronics can be installed as wall mount or 2" pipe mount type. Necessary mounting brackets

with u-bolt and clamps are to be used for 2" pipe mount option.

The interconnection cable between remote control electronics unit and the probe unit shall have a maximum length of 1000 metres. The recommended cable shall be of 2-core twisted pair shielded cable, with a size of minimum 2 x 0.75mm².

Important installation notes:

- Enclosure is W/P only when all entries and joints are suitably sealed.
- Use certified cable gland when not supplied by SWITZER.
- Mounting plate and clamps are not supplied for Integral type Level Switches.

CAUTION

1. During installation, proper care must be taken to avoid causing damage to the sensing probe outer insulation.
2. Isolate probes from severe motion in the tank because surface turbulence may cause signal deviation.
3. Ensure the grounding of the probe enclosure with tank wall is proper to have adequate signal generation for the control electronics.
4. When an insulated probe is used in a hazardous and/or abrasive medium, the probe should be inspected at regular intervals for nicks, cuts, or abrasions, which may ruin the integrity of the insulation. In the event that wear is found, replace the probe or consult the factory for further instructions. This procedure is critical in vessels containing hazardous media.

MOUNTING

Model K-5711 – Single Point Level Switch:

Single point level switch can be mounted both vertically and horizontally. When the probe is mounted vertically, the setting of the level switch is performed with the media on any part of the sensing element. When the probe is mounted horizontally, the location of the probe is the point at which the level switch is calibrated for relay actuation.

For single probes with guard, it is to be ensured that the switch calibration is carried out when the media is in contact with the sensing element of the probe. The calibration of the level switch does not get affected when the media is in contact with the guarded portion of the probe.

Model K-5712 – Dual Point Level Switch:

All dual point level switches are to be mounted vertically. Probes of dual point level switches are not to be mounted horizontally.

WIRING

All terminals are screw clamp type suitable to accommodate 2.5 Sq.mm wires. One terminal can accommodate only one wire of indicated size and is not advisable to join more than one wire into one terminal opening.

For Integral mount configuration:

Terminals are provided on both the power supply board and signal board. The power terminal to power up the level switch are provided on the power supply board on one side of the mounting plate. The output relay contact terminals are provided on the signal board on the other side of the mounting plate. Two 1/2" NPT cable entries are provided in the enclosure for taking out the electrical connections.

For Remote mount configuration:

The power supply terminals and the output relay contact terminals are the same as described in Integral mount option. In addition to this the interconnection wiring between Remote Control unit with probe Pulse Transmitter unit is to be established.

The probe housing is provided with one 1/2" NPT cable entry. The remote mount control unit is provided with two similar entries.

All figures available in this section represents Model K-5712 with enclosure cover removed. For Model K-5711, they are identical except that the Relay contact Terminals of Setpoint-2 are not present.

Fig-1: Signal and Relay output contact terminal location for Integral Mount Level Switch – Control Unit with Level Probe

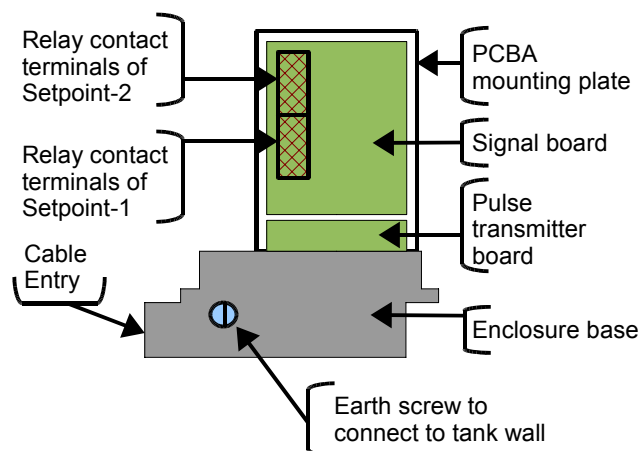

Fig-2: Signal and Relay output contact terminal location for Remote Mount Level Switch – Control unit away from Level Probe

Pulse Transmitter board is not present in the remote control unit and is installed in the probe unit.

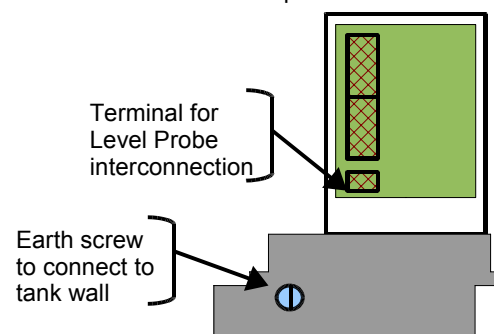
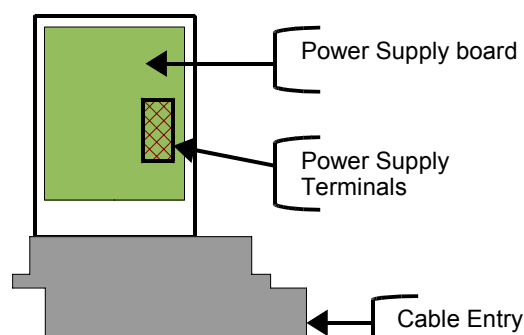

Fig-3: Power supply terminal location for both Integral and Remote Mount Level Switch



The details of the terminal connections are provided in the next set of figures Fig-4, Fig-5, Fig-6 for AC power supply board, DC power supply board and Signal board.

Fig-4: Terminals on AC Power Supply board

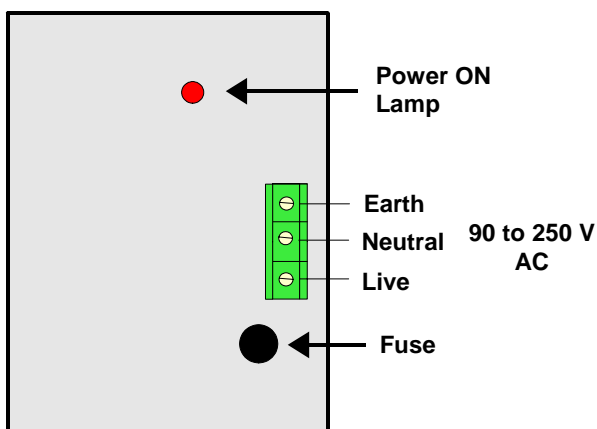

Fig-5: Terminals on DC Power Supply board

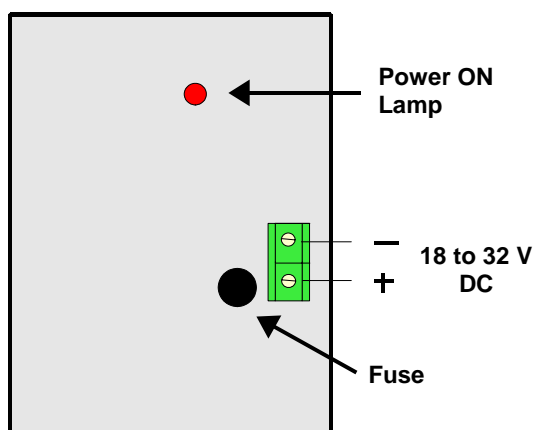
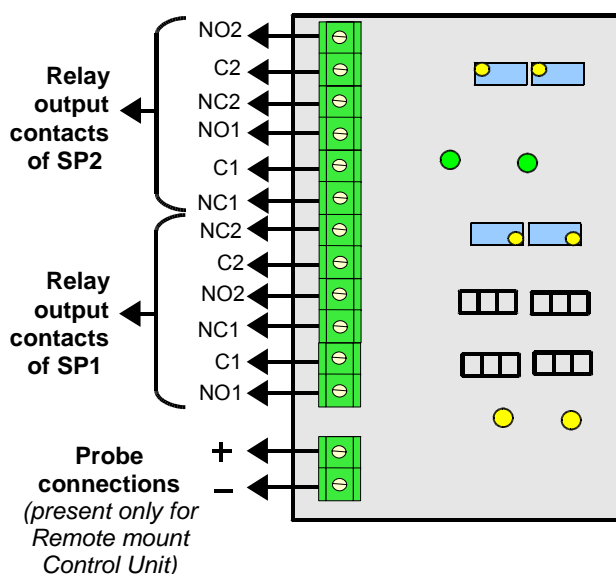

Fig-6: Terminals on Signal board



Notes: Refer to above Fig-6.

1. For Integral mount configuration of Model K-5711 and K-5712, Probe Connections terminals are NOT provided on the Signal board.
2. For Model K-5711, Setpoint-2 (SP-2) components are

NOT present on the PCB.

3. For Model K-5711, Relay output contact terminals for SP2 are NOT present.

Fig-7: Terminal arrangement on probe unit (top view with cover removed) in Flameproof Housing – For Remote mount type

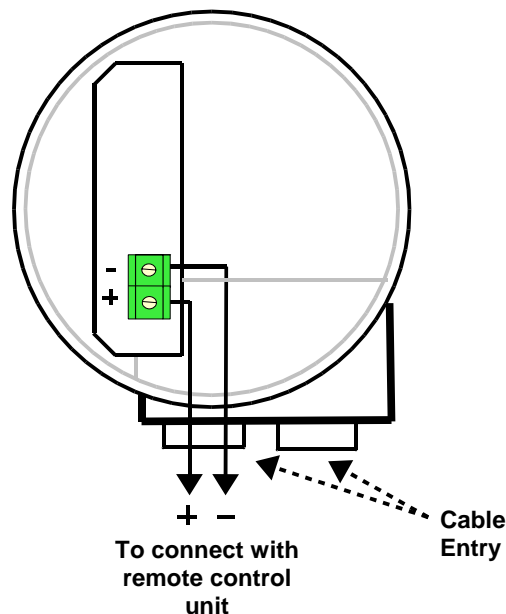
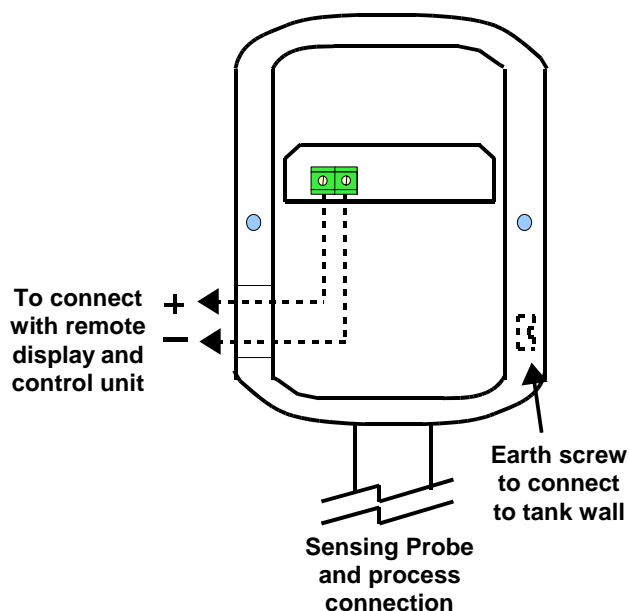

Fig-8: Terminal arrangement on probe unit (top view with cover removed) in Weather Proof housing – For Remote mount type



CALIBRATION AND SETTING OF LEVEL SWITCH

Power up the instrument with the appropriate power supply marked on the name plate of the instrument. Power on lamp (red LED) on the power supply board will be ON.

Refer to Fig-9, Fig-10 & Fig-11 for jumper selection requirements before commencing calibration and setting of Level Switch.

Fig-9: Signal board details

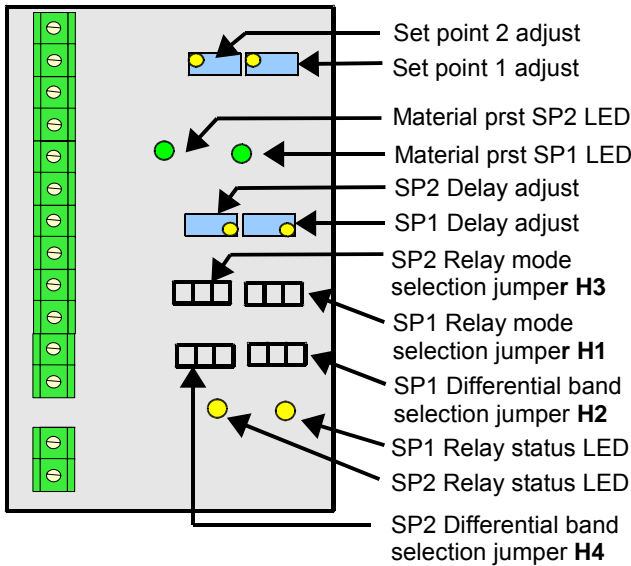

2. Fill the tank up to the required set point level.
3. The SP1 green LED and yellow LED will be ON.
4. Turn set point pot P1 clockwise, till the green & yellow LEDs goes OFF.
5. Slowly trim the set point pot in both the directions for precise setting.
6. Increase the tank level to check whether the relay comes ON immediately.
7. Decrease the tank level to check whether the relay goes OFF.
8. This completes calibration and setting for Setpoint-1 (SP-1).

Table – 1 : Relay status table for Narrow Differential

Relay Mode	Jumper position		Relay status (both SP1 & SP2)	
	SP1	SP2	Media above set value	Media below set value
Normal	H1-N	H3-N	ON	OFF
Failsafe	H1-F	H3-F	OFF	ON

Jumper selection options

Fig-10: Relay mode selection jumper – H1 & H3

Jumper H1 will select relay mode for Setpoint-1.
Jumper H3 will select relay mode for Setpoint-2.



N – Normal mode F – Failsafe mode

Fig-11: Differential band selection jumper – H2 & H4

Jumper H2 will select differential band for Setpoint-1.
Jumper H4 will select differential band for Setpoint-2.



N – Narrow differential band W –Wide differential band

Adjustments and setting for Narrow Differential mode:

This calibration is applicable for both models K-5711 and K-5712.

Initial settings:

1. Place Differential Band selection jumper in position **H2-N & H4-N**.
2. Place Relay Mode selection jumper in position **H1-N & H3-N**.
3. Turn the delay pot fully counter clockwise to ensure zero time delay during calibration.

Calibration procedure:

Relay in Normal mode. Refer below status Table-1. The below procedure is described for Setpoint-1. Follow similar procedure for Setpoint-2 adjustment by using the appropriate potentiometers.

1. Turn set point pot **P1** fully counter clockwise.

Adjustment and setting for Wide Differential mode:

This calibration is applicable only for model K-5712. Refer to Fig-7, Fig-8 & Fig-9 for jumper selection requirements before commencing calibration and setting of Level Switch.

Initial settings:

1. Place Differential Band selection jumper in position **H2-N & H4-N**. Later on, after completing the calibration this jumper is to be changed to **H2-W & H4-W**.
2. Place Relay Mode selection jumper in position **H1-N & H3-N**.
3. Turn the delay pot fully counter clockwise to ensure zero time delay during calibration.

Calibration procedure:

1. Fix the wide band for relay operation by identifying the LOW and HIGH level setpoints.
2. Setpoint-1 is to be set for HIGH tank level.
3. Setpoint-2 is to be set for LOW tank level.
4. Both Setpoint-1 & Setpoint-2 are to be initially calibrated and set independently in the Narrow differential mode.
5. Follow the same calibration procedure as described above for Narrow Differential mode.
6. Change Differential band jumper from **H2-N to H2-W** and **H4-N to H4-W** for the wide band differential mode to function. *If this jumper is not changed the relays will operate in the Narrow differential band at the calibrated tank level.*
7. Check for proper functionality in the Wide Differential mode as per the status Table-2 below.

Table-2: Wide band mode relay status

Level status in Tank	Level change mode	SP1 – High Relay Status	SP2 – Low Relay Status
$L < SP2 < SP1$	Increasing	OFF	ON
$SP2 \leq L < SP1$	Increasing	OFF	ON
$SP2 < SP1 \leq L$	Increasing	ON	OFF
$SP2 < SP1 < L$	Decreasing	ON	OFF
$SP2 < L < SP1$	Decreasing	ON	OFF
$L < SP2 < SP1$	Decreasing	OFF	ON

Graphical representation of Wide Band & Narrow band operational modes

(a) Setpoint-1 relay status (HIGH relay) in Wide Band

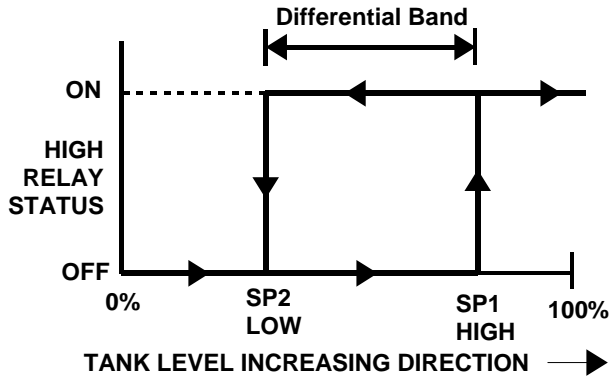

(b) Setpoint-2 relay status (LOW relay) in Wide Band

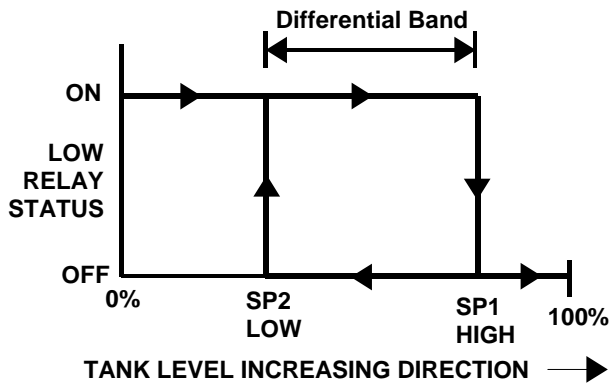

(c) Setpoint-1 & 2 relay status in Narrow Band – Normal mode

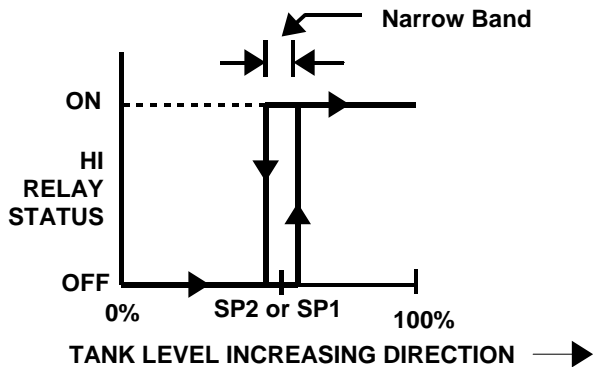

Wide Differential band mode – Relay Status after power interruption

Refer to Table-3 for status of Level Switch which is configured to operate in the Wide Differential mode, when there is a power supply interruption.

1. The wide differential configuration is possible only in one mode with SP2 acting as LOW setpoint and SP1 acting as HIGH setpoint. The logic will not operate vice-versa. This is because the configuration diodes are permanently installed.
2. For pump ON-OFF control, where the tank is to be filled up when the level reaches low and filling stops when level reaches high, it is necessary to use SP2 relay contacts (Normally Open) only to operate the pump. In this case, the pump switches ON when the level

reaches LOW point and the pump switches OFF when the level reaches HIGH point.

3. During any interruption of power to the instrument, the output relay contacts restores to the original condition when PV is either below or above both setpoints. Refer to above status table.
4. During any interruption of power to the instrument and when the PV is between the 2 setpoints, the output relay contact of SP2 and SP1, ALWAYS returns to the safest mode. That is, SP2 relay is in the OFF condition which means the pump is NOT switched on. The pump gets switched on again only when the level falls below the LOW setpoint.

Table-3:

Level in tank	Before Power Interruption		After Power is restored	
	SP1 High Relay Status	SP2 Low Relay Status	SP1 High Relay Status	SP2 Low Relay Status
$L < SP2 < SP1$	OFF	ON	OFF	ON
$SP2 < L < SP1$	OFF	ON	ON	OFF
$SP2 < SP1 < L$	ON	OFF	ON	OFF

TIME DELAY ADJUSTMENT

Time delay adjustment is provided for each of the setpoint. When delay adjustment is set, the relay operates after the set time when the media level crosses higher than the setpoint. This delay will NOT occur when the media level is decreasing in the tank, which means that the relay will be operating instantaneously when the media level falls below the setpoint.

The delay is set by a continuously adjustable potentiometer. The time delay potentiometer are located on the Signal board. Refer to Fig-7.

Time Delay range

When the delay potentiometer is rotated fully counterclockwise, the delay is 0 secs. When the delay potentiometer is rotated fully clockwise, the delay is about 20 secs. The user can set it at any position based on the above limits to achieve suitable time delay.

TECHNICAL SPECIFICATIONS

Characteristics	Specifications
Model	K-5711: Single point Level Switch K-5712: Dual point Level Switch
Input	Level probe – Capacitance type
Range	0 to 5000 pF
Power supply	(1) AC: 90 to 250V; (2) DC: 18 to 32V
Power status	Power ON indication through Red LED
Output contact specifications:	
No. Set points	K-5711: One; K-5712: Two
Set point range	Within instrument measuring range
Relay contact rating	6A at 250V AC/ 28V DC K-5711: One DPDT relay contact K-5712: One independent SPDT relay contact for each setpoint.
Time delay	0 to 20 secs adjustable through potentiometer

Characteristics	Specifications
Relay status	Relay ON indication through Yellow LEDs for each setpoint
Differential Range	<p>K-5711: Fixed differential only. 2-10pF (approx. 0.2% of calibrated input capacitance value)</p> <p>K-5712: <u>Option-1:</u> Fixed differential - Both setpoints operate independently. 2-10pF (approx. 0.2% of calibrated input capacitance value) <u>Option-2:</u> Both setpoints interlocked to provide wide differential. 0 to 5000pF. Selection through jumper.</p>
Relay mode	Normal or Failsafe - Jumper selectable
Housing configuration	
Probe	<p>Integral: GK cast aluminium, F/P and W/P</p> <p>Remote: GN cast aluminium for W/P; GK cast aluminium for F/P</p>
Probe mounting	<p>K-5711: Horizontal and vertical K-5712: Vertical only</p>
Control Unit	<p>Integral option: Present in the probe unit</p> <p>Remote: GK cast aluminium, F/P and W/P</p>
Control unit mounting	<p>Integral: Present along with the probe mounted on tank</p> <p>Remote: Wall mounting; Surface mounting; 2" pipe mounting</p>
Cable between probe & remote electronics	Customer scope. 2-core shielded cable, recommended size of 2x0.75mm ² , maximum length of 1000 metres.
Ambient conditions	Temperature – 0 to 60°C; Relative humidity – 95% (max.)